

# Green helium for a hi-tech world.



Ready to drill  
in Q3 2023.

Justyn Wood  
Co-founder and CEO

18 July  
2023

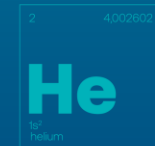



---

# Disclaimer

This presentation has been prepared by Noble Helium Limited (ACN 603 664 268) (**Noble Helium** or **Company**) and contains background information about Noble Helium's current situation at the date of this presentation. The presentation is in summary form and does not purport to be all inclusive or complete.

Noble Helium has issued a prospectus dated 18 February 2022 in connection with its proposed initial public offering of shares and listing on the Australian Securities Exchange (**Prospectus**). Accordingly, this presentation should be read in conjunction with the Prospectus. Any person who wishes to apply for shares in Noble Helium will need to apply under the Prospectus by completing an application form accompanying the Prospectus. Comprehensive details regarding Noble Helium and its projects are set out in the Prospectus.

Recipients should conduct their own investigations and perform their own analysis in order to satisfy themselves as to the accuracy and completeness of the information, statements and opinions contained in this presentation. This presentation is for information purposes only. Neither this presentation nor the information contained in it constitutes an offer, invitation, solicitation or recommendation in relation to the purchase or sales of shares or other securities in any jurisdiction. This presentation is not a prospectus, product disclosure statement or other offering document under Australian law (and will not be lodged with the Australian Securities and Investments Commission) or any other law.

This presentation does not constitute investment or financial product advice (nor tax, accounting or legal advice) and has been prepared without taking into account the recipient's investment objectives, financial circumstances or particular needs and the opinions and recommendations in this presentation are not intended to represent recommendations of particular investments to particular persons. Recipients should seek professional advice when deciding if an investment is appropriate. All securities involve risks which include (among others) the risk of adverse or unanticipated market, financial or political developments. Details regarding the risks associated with an investment in the Company are set out in the Prospectus.

This presentation may include forward-looking statements. Forward-looking statements are only predictions and are subject to risks, uncertainties and assumptions which are outside the control of Noble Helium. Actual values, results or events may be materially different to those expressed or implied in this presentation. Given these uncertainties, recipients are cautioned not to place reliance on forward looking statements.

No reserves have been assigned in connection with the Company's property interests to date, given their early stage of development. Unrisked Prospective Helium Volumes have been defined. However, estimating helium volumes is subject to significant uncertainties associated with technical data and the interpretation of that data, future commodity prices, and development and operating costs. There can be no guarantee that Noble Helium will successfully convert its helium resource to reserves and produce that estimated volume.

## Competent Person's Statement

The prospective volumes are for helium, which are not hydrocarbons. However, Netherland, Sewell & Associates, Inc. have used the definitions and guidelines set forth in the 2018 Petroleum Resources Management System (**SPE-PRMS**) approved by the Society of Petroleum Engineers as the framework to classify these helium volumes as "prospective". The SPE-PRMS is specifically designed for hydrocarbons, which helium is not, however the principles and methods for hydrocarbon gas resource estimation are directly applicable to helium gas volume estimation.

The prospective helium volumes included in this presentation should not be construed as petroleum reserves, petroleum contingent resources, or petroleum prospective resources. They represent exploration opportunities and quantify the development potential in the event a helium discovery is made. The information in this presentation which relates to prospective helium volumes is based on, and fairly represents, in the form and context in which it appears, information and supporting documents prepared by, or under the supervision of, Alexander Karpov and Zachary Long .

Alexander Karpov is an employee of Netherland, Sewell & Associates, Inc. Alexander Karpov attended Texas A&M University and graduated in 2001 with a Master of Science Degree in Petroleum Engineering, and attended the Moscow Institute of Oil and Gas and graduated in 1992 with a Bachelor of Science Degree in Petroleum Geology. Alexander Karpov is a Licensed Professional Engineer in the State of Texas, United States of America and has in excess of 26 years of experience in petroleum engineering studies and evaluations. Alexander Karpov has sufficient experience to qualify as a qualified petroleum reserves and resources evaluator as defined in the ASX Listing Rules.

Zachary Long is an employee of Netherland, Sewell & Associates, Inc. Zachary Long attended Texas A&M University and graduated in 2005 with a Master of Science Degree in Geophysics, and attended the University of Louisiana at Lafayette and graduated in 2003 with a Bachelor of Science Degree in Geology. Zachary Long is a Licensed Professional Geoscientist in the State of Texas, United States of America and has in excess of 16 years of experience in geological and geophysical studies and evaluations. Zachary Long has sufficient experience to qualify as a qualified petroleum reserves and resources evaluator as defined in the ASX Listing Rules.

Alexander Karpov, Zachary Long and Netherland, Sewell & Associates, Inc. have each consented to the inclusion in this presentation of the matters based on this information in the form and context in which they appear.

# The pitch

A ground-floor investment in the potential discovery and development of the world's largest **green helium** reserve.

**01**  
Favourable market



**02**  
Experienced team



**03**  
World class assets



**04**  
Green helium

<sup>2</sup>  
**He**  
Helium

# There's no technology without helium.

It's an irreplaceable input for many important technologies with significant demand growth from manufacturers of semiconductors used in computers, mobile phones, cars, (even kids' toys).

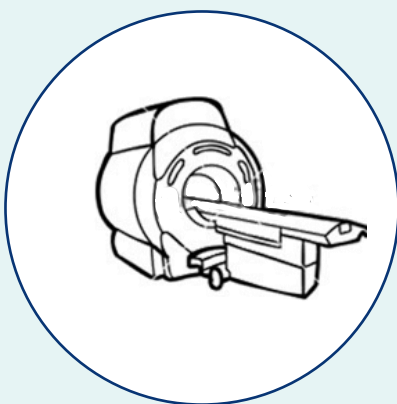

MRI

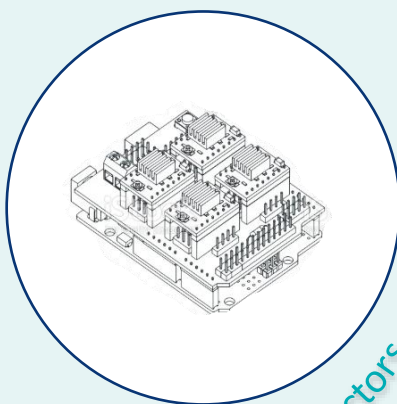

Semi-conductors

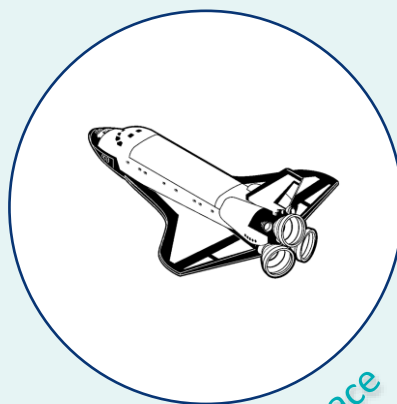

Aerospace

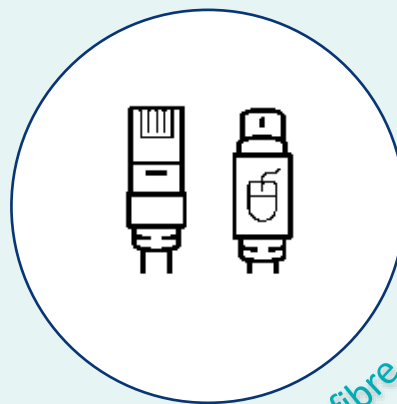

Optical fibre



Cryogenics

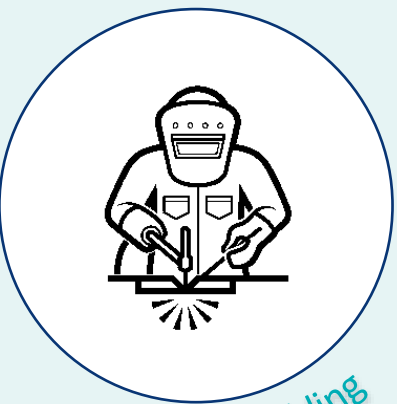

Welding

# AI needs computer chips. Computer chips need helium.

Helium is a key manufacturing ingredient required for the computer chips that are the “picks and shovels” of this new AI rush.

AI is escalating. Some of the world's largest chip producers have seen their market caps grow by billions of dollars this year.

- NVIDIA's share price is up ~198%<sup>1</sup>
- AMD's share price is up ~94%<sup>2</sup>
- TSMC's share price is up ~29%<sup>3</sup>
- Intel's share price is up ~34%<sup>4</sup>

**Bloomberg**

## Nvidia Nailed Bet on AI Trend in Surge Toward \$1 Trillion

- Company becomes poster child for how to make money in AI
- It's poised to be **first chipmaker to join the \$1 trillion club**

**Bloomberg**

## TSMC Hits \$500 Billion Value as Investors Clamor for AI, Chips

- Chipmaker to Nvidia and Apple remains Asia's biggest company
- **Investors are piling into stocks from Nvidia to Oracle**

1. NVIDIA Corp. 1 Jan 2023 US\$143.15. 16 June 2023 US\$426.53.  
2. Advanced Micro Devices (AMD) – 1 Jan 2023 US\$64.02. 16 June 2023 US\$124.24  
3. Taiwan Semiconductor Manufacturing – 1 Jan 2023 NT\$453.00. 16 June NT\$587.00  
4. Intel Corporation. 1 Jan 2023 US\$26.73. 16 June 2023 US\$35.82

# That's why the value of the global helium market is growing.

The global helium market size is expected to grow from an estimated \$5 billion in 2023 to over

## \$8.00 billion in 2030

Estimated global helium market  
US\$ billions

Actual  
Forecast

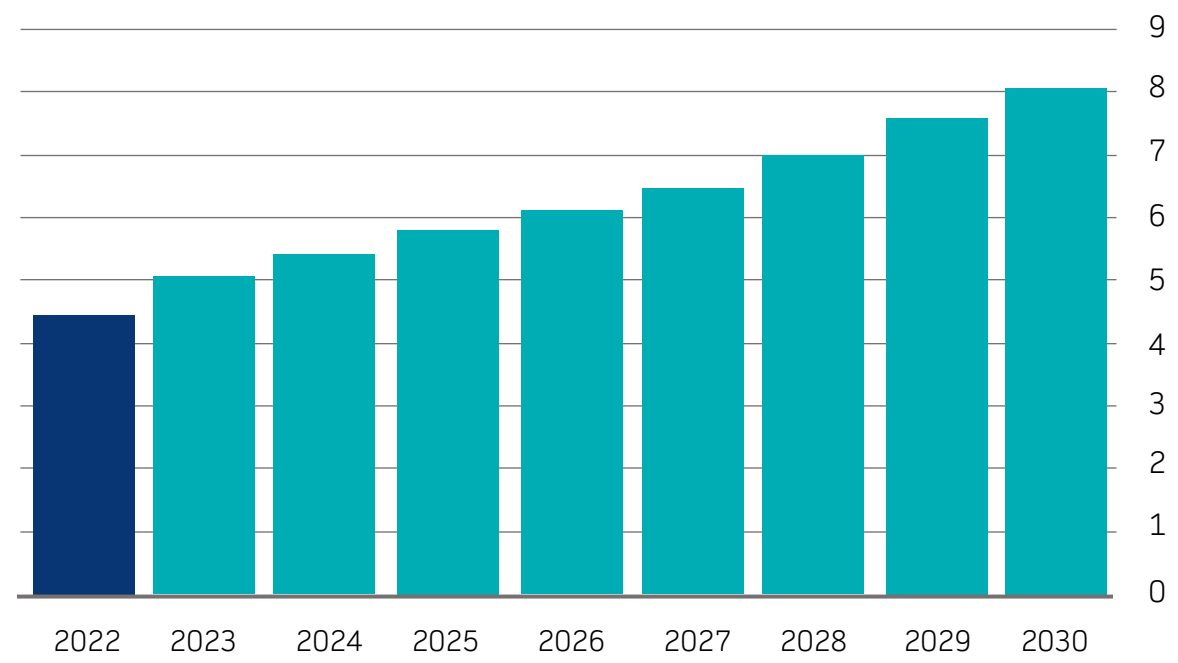

Source: The Business Research Company, Helium Global Market Report 2023  
Published January 2023



---

## Helium supply is fragile. Very fragile.

---

Currently experiencing the fourth worldwide helium shortage since 2006.



USA - BLM federal reserve depleted



Russia – around one third of world supply by 2027 but troubled by Amur plant startup fires coupled with growing geopolitical tensions.



Qatar – 30% of world supply. Embargoed for six weeks in June 2017



Algeria – normally 8% of world supply; Skikda LNG feed redirected to Europe.

---

# Decoupling from gas production, and geopolitical diversification is the best solution for a secure global helium supply chain.

The helium price is surging with transition to market pricing and fragile supply.

March 2023

Long-term contract bulk liquid helium pricing

US\$450/Mscf

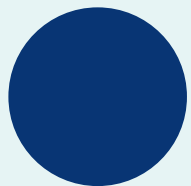

That's 50 times the price of LNG!

Historical price of bulk liquid helium  
US\$/thousand standard cubic feet (Mscf)

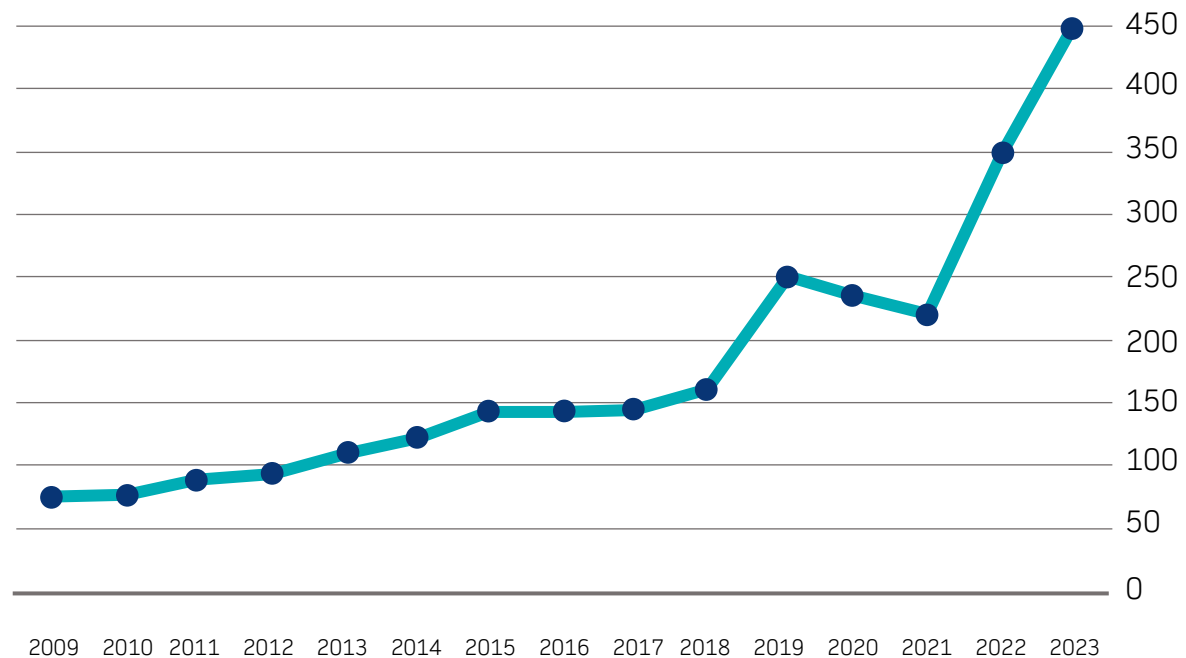

Source: Kornbluth Consulting LLC



# Noble Helium is led by experienced oil and gas pioneers.



**Shaun Scott**  
Executive Chairman

Helped pioneer Queensland coal seam gas industry from “novelty” status to a \$20 billion per year export industry.

As CEO of Arrow Energy Ltd, Shaun led the growth of that business from a \$20m coal seam gas explorer until its \$3.5 billion acquisition by Shell and Petro-China.

Highly experienced independent non-executive director on publicly listed and private company boards. Currently a non-executive director of ASX listed Comet Ridge Ltd.



**Justyn Wood**  
Chief Executive Officer

The Exploration Geophysicist who helped put the East African Rift System on the world oil and gas map.

Justyn has nearly 30 years of E&P industry experience in both technical and management roles at Hardman Resources, Chevron Australia, Repsol Australia and Oil Company of Australia.

Made key contributions to the first oil discoveries in South America’s Guyana margin as well.



**Prof Andrew Garnett**  
Non-Executive Director

Prof. Garnett is currently the Director of the University of Queensland’s research Centre for Natural Gas (CNG), working closely with the main LNG project proponents in Queensland, Australia. Has over 25 years of international experience in senior technical, management and executive roles in the upstream oil and gas sector including with Shell and Schlumberger.



**Eddie King**  
Non-Executive Director

Former investment banker and current director of CPS Capital Group, a stockbroking and corporate advisory firm specialising in small to medium high growth companies. Executive Chairman of Rubix Resources Ltd (ASX: RB6), Executive Director of Ragnar Metals Ltd (ASX: RAG), Non-Executive Chairman of Bindi Metals Ltd (ASX: BIM), Eastern Resources Ltd (ASX: EFE) and Great Northern Minerals (ASX: GNM) plus a Non-Executive Director of M3 Mining Ltd (ASX: M3M), Queensland Pacific Metals Ltd (ASX: QPM)



**Kent Masters**  
Anchor Investor

A core early investor in Noble Helium, Kent is Chairman, CEO and President of Albermarle, one of the world’s largest lithium companies. As former Executive Director of Linde, the world’s largest industrial gas company by market share and revenue (capped at ~US\$160B), Kent held responsibility for the Americas, Africa, East Asia, South Pacific. And helium. He knows his industrial gases and has a network that stretches across the world and includes project developers and off-takers.



Noble Helium also commissioned, and has exclusively licensed, the world’s first ‘Helium Atlas’ from Global Helium Resources, who’s two foremost helium experts – Dr. Jon Gluyas of Durham University and Dr. Chris Ballentine of Oxford – were key in its development.

# Four primary helium projects along Tanzania's East African Rift System.

Noble's resource has the potential to be the world's third largest helium resource, and the largest ever helium reserve not associated with hydrocarbons.

Our projects are located along the East African Rift System (EARS) and are Basin Margin Fault Closure (BMFC) plays.

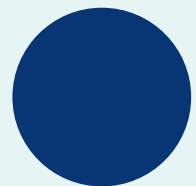

There is a 100% success rate for EARS oil and gas wells that are BMFC plays.

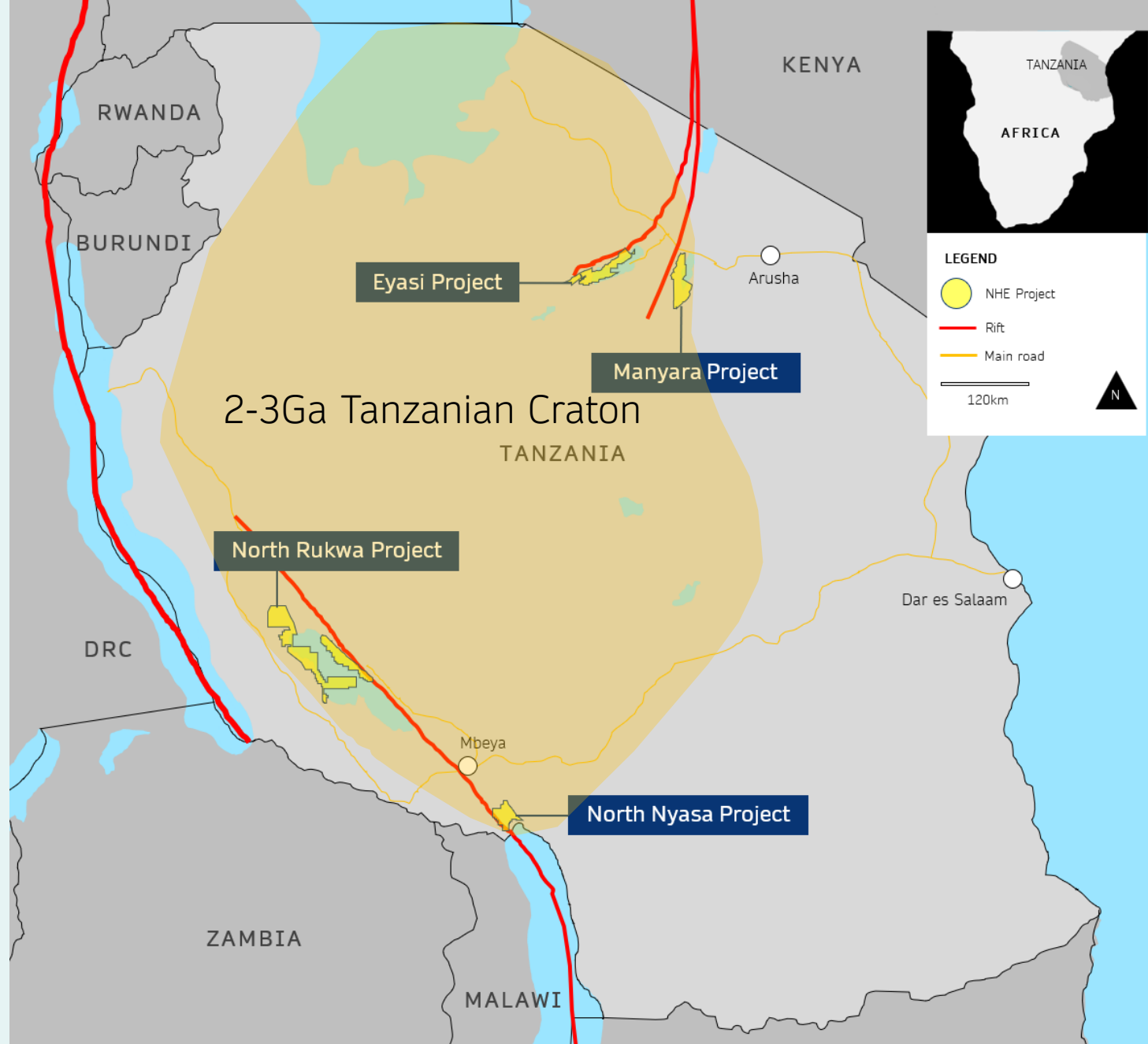

We're drilling our first hole next quarter.

Mbelele BMFC will be drilled using a simple onshore shallow vertical well.

- Drilling funded by recent \$13.5m capital raising.
- Mbelele is just one of 10 identified targets at North Rukwa.
- Mbelele, Pegere and Kachina-Dagaa targets have a combined, company-estimated mean helium prospective resource of 39BCF.

39 billion cubic feet value

**US\$18 billion**

@US\$450/Mscf of liquid helium

# NORTH RUKWA PROJECT

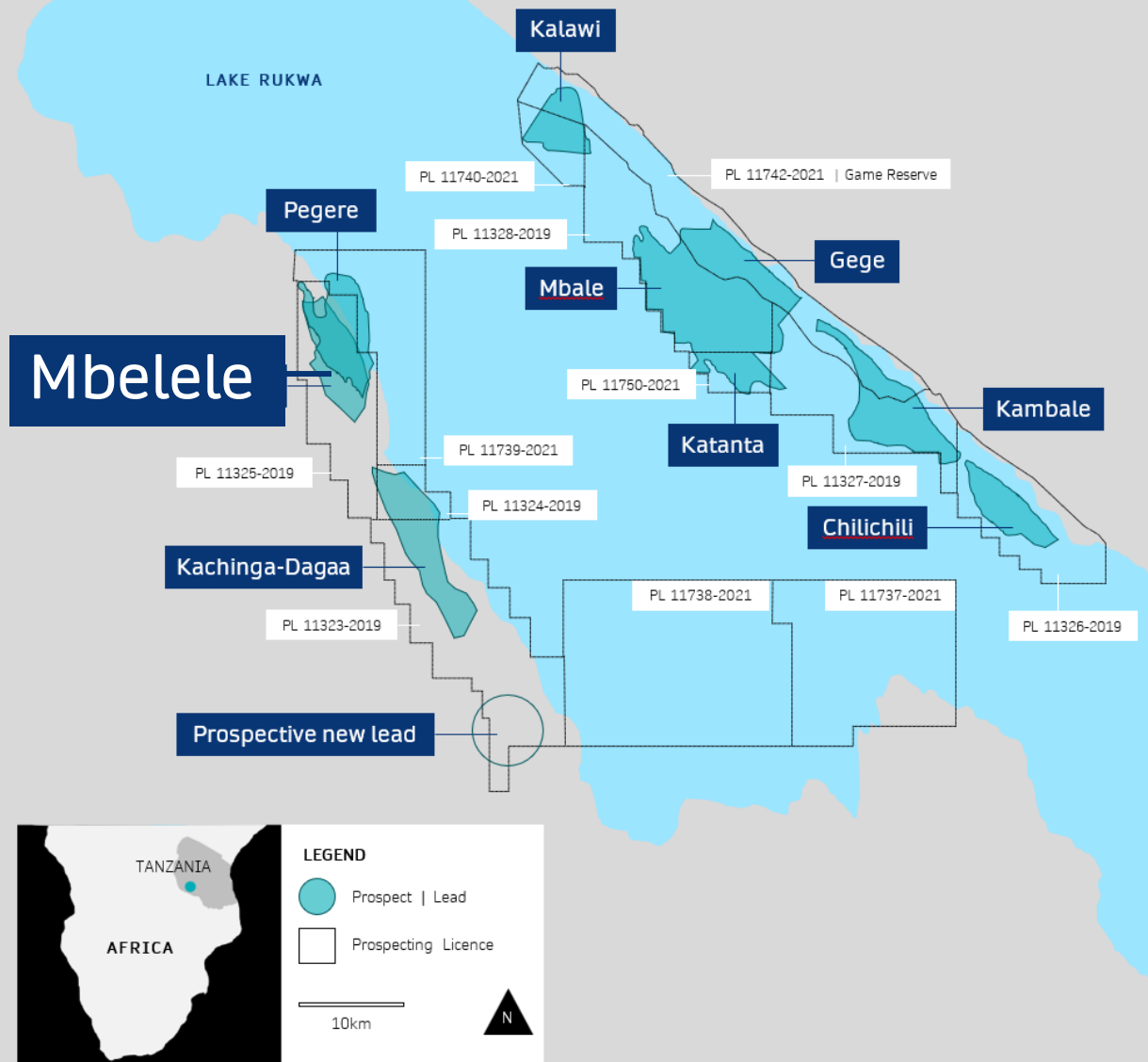



We've spent seven years pinpointing these wells.

Our fully georeferenced Petrel™ subsurface model visualises the elements of the Helium System, which are all present and in the correct sequence to host helium accumulations in the North Rukwa.

Comprehensive de-risking program:

- 2D and 3D seismic surveys
- Soil gas surveys
- airborne gravity gradiometry
- reservoir and seal studies and
- leading-edge helium charge modelling.

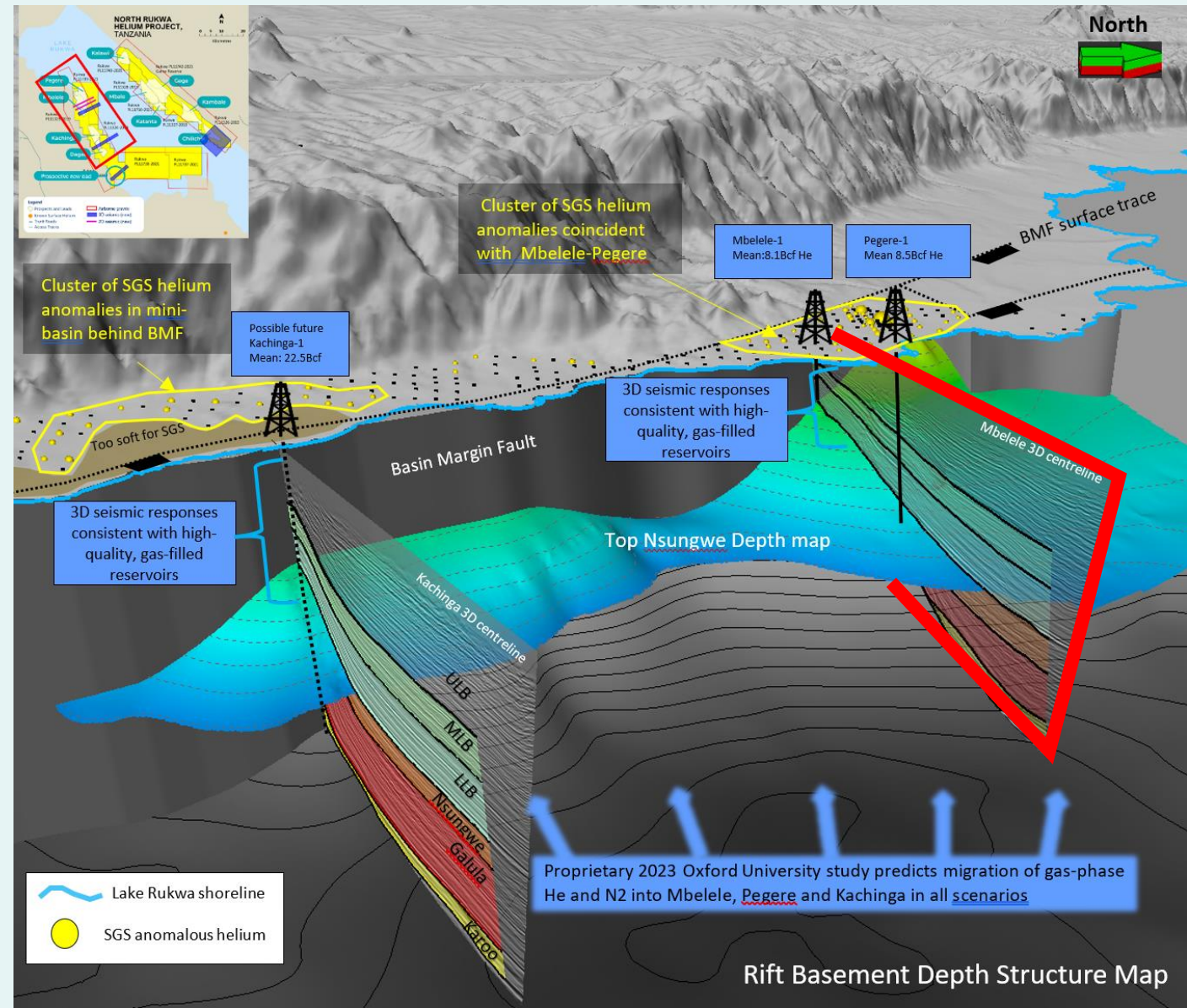



# Mbelele geophysics shows volumes consistent with 16.5Bcf mean resource

- Mbelele BMFC 3D seismic provides strong indications of “stacked pay” - gas trapped at four separate depth intervals
- Amplitude Vs Offset analysis also supports trapped gas
- Helium anomalies in overlying soil gas indicates helium within the BMFC-trapped gas

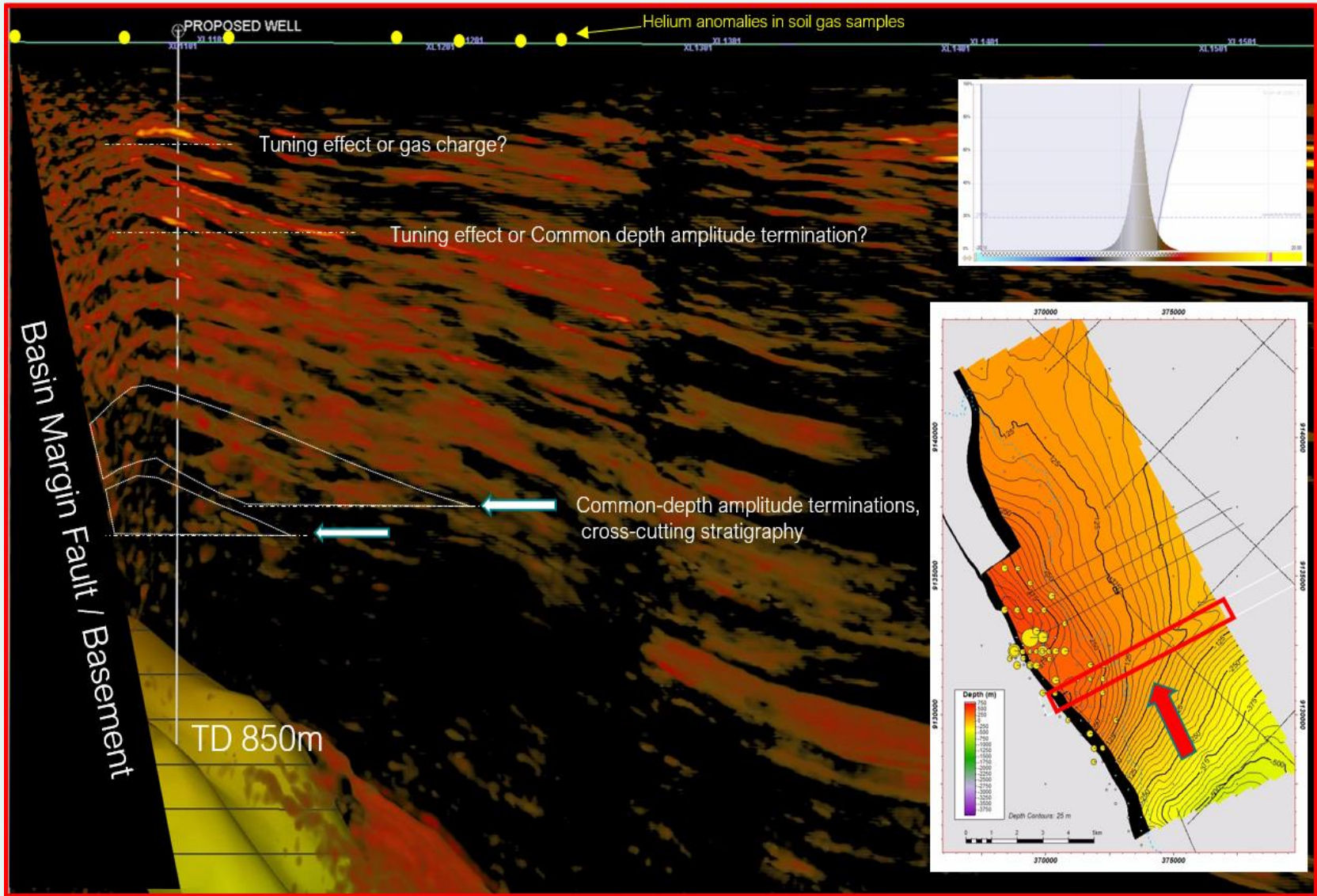

# Our green helium doesn't come from fossil fuels.

Surface gas sampling in and around the Noble's tenements indicate that helium trapped underground is "Primary Helium" (associated with nitrogen rather than hydrocarbon gas).

- 95% of the world's current helium supply is associated with fossil fuel energy production.
- Our helium liquefaction plant will be powered by 100% renewable hydro-electric power
- Critical materials such as green helium has sustainability credentials which are highly desirable.

## Primary and Green Helium

In Tanzania, Primary Helium is being released from basement with Nitrogen and being trapped as a mixed gas in layers of reservoir and seal rocks, just like a conventional natural (methane) gas field.

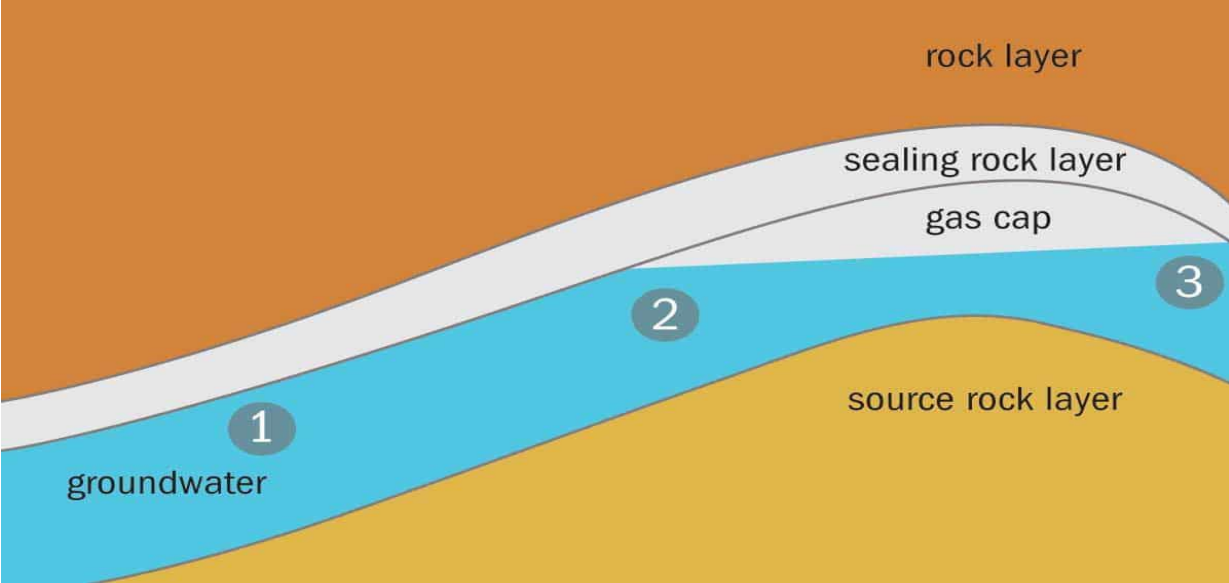

## Sensible path to market.

- Strong interest from potential off-takers to manage logistics and fund downstream facilities.
- Helium liquefaction plant on site. Early monetisation options being explored, including rental or existing plant.
- Simple field development and gas gathering system.
- Off-taker would truck liquid helium iso-containers on black-top road to Port of Dar es Salaam.
- Direct access to national power grid and water.

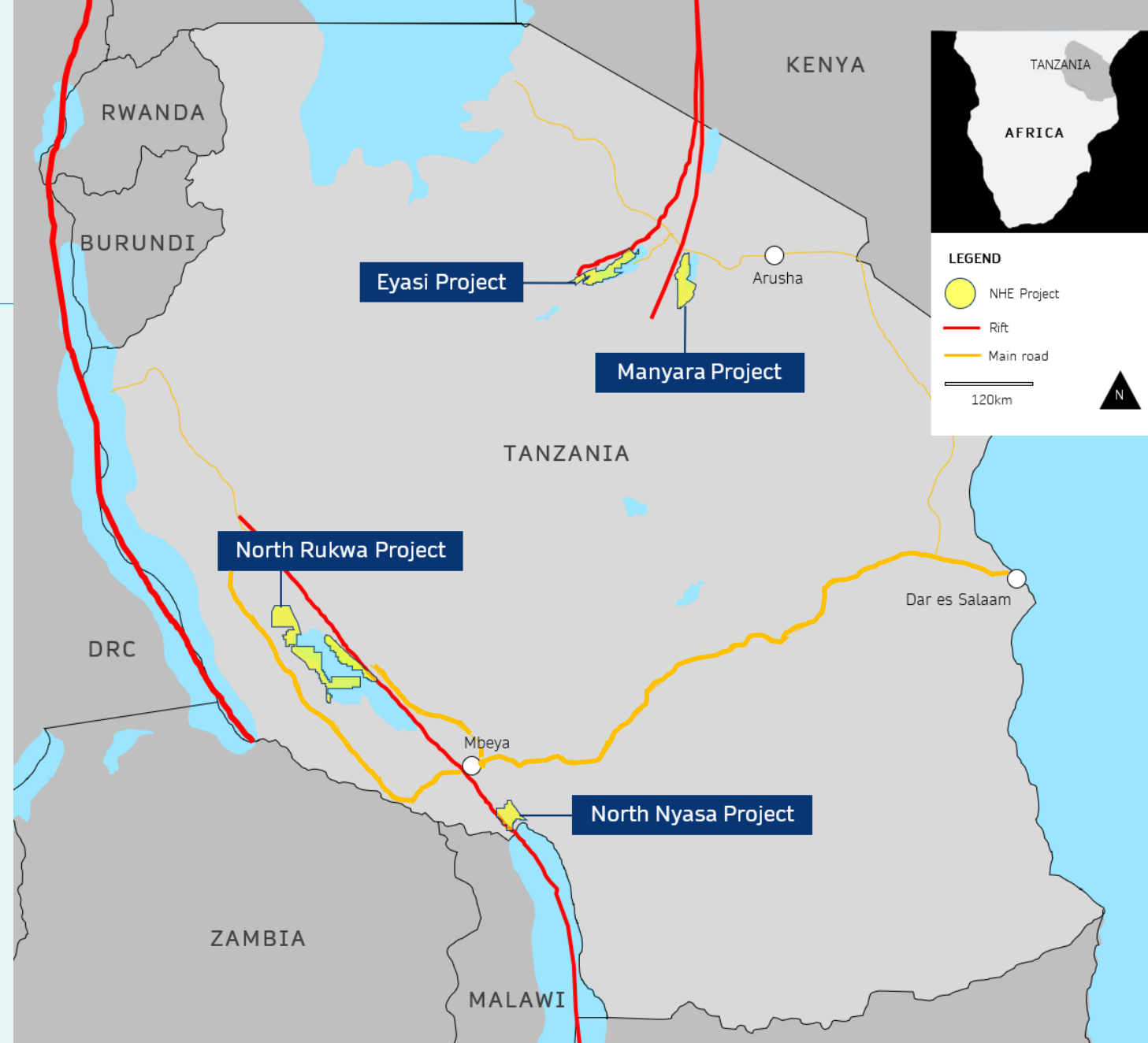

## The maths.

As a gas, helium has similar exploration/production costs per Mscf as traditional oil and gas but requires significantly less capital as much smaller volumes are required for a highly profitable project.

Discovering a 6Bcf recoverable helium resource is a company maker!

## Worked example

To achieve an annual production of

**850,000**

Mscf of liquid helium

The estimated total CAPEX 2023-2027 would be

**US\$305m**

And the estimated total OPEX (2027) would be

**US\$25m**

Estimated ultimate recovery

**12Bcf**

Over 20 years  
33% year 13 to depletion

Pricing

**US\$450**

Mscf of liquid helium

First full year production

	US\$M
Revenue	\$382.50
OPEX	\$25.00
Depreciation	\$15.25
Gross Margin	\$342.25



# Corporate snapshot.

Share price  
**\$A0.21c**

14 July 2023  
 52 week high \$0.34, low \$0.135

Market capitalisation  
**A\$56.13m**

14 July 2023

Debt  
**Zero**

31 March 2023

Shares on issue  
**267m**

16 June 2023

Cash  
**A\$3.0m**

31 March 2023

Total options  
**104m**

31 March 2023

## ASX Share price performance (\$A)

12 months to 14 July 2023

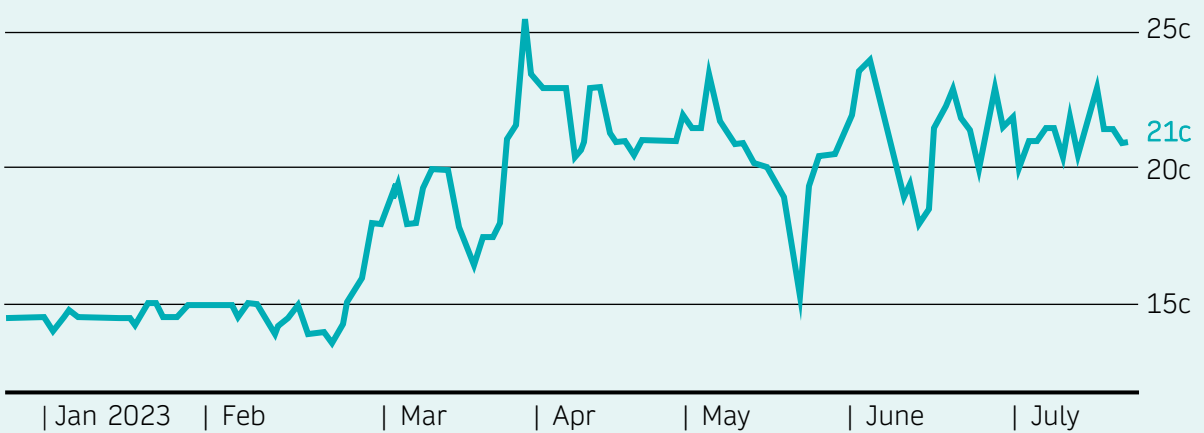

## Share register

Figures shown are approximate as at 3 February 2023

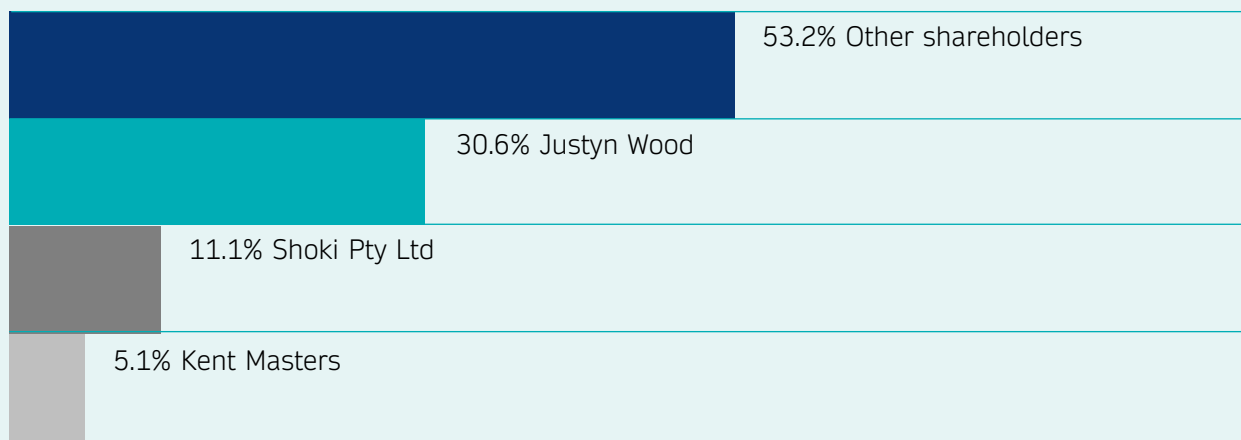

# Invest in the future of helium.

A ground-floor investment in the potential discovery and development of the world's largest **green helium** reserve.

Drilling in Q3.

**01**  
Favourable market



**02**  
Experienced team



**03**  
World class assets



**04**  
Green helium

<sup>2</sup>  
**He**  
Helium

# Contact

T: + 61 (0)8 9481 0389

E: [info@noblehelium.com.au](mailto:info@noblehelium.com.au)

## Registered Office

Noble Helium Limited  
Level 8, London House  
216 St. Georges Terrace  
Perth WA 6000

